

“Viewing angels”: a not so rare species...

by Michael E. Becker



Michael E. Becker is the founder and CEO of Display-Metrology & Systems (DM&S) in Karlsruhe, Germany (<http://www.display-metrology.com>), a company providing customer specific and off-the-shelf hard and software solutions for measurement and rating of electronic display visual performance. After completion of his PhD at the University of Karlsruhe and prior to the establishment of DM&S he worked for autronic-Melchers (1985-2001), first as section head, and from 1993 on as a managing director, developing and marketing a range of instruments for measuring LCD visual performance and LCD material and device properties and a software package for numerical modeling of LCD electro-optical performance (DIMOS). Michael has been actively contributing to a variety of international standards for electronic visual display devices (IEC TC110 and ISO TC159/SC4/WG2). In 2006 he received the IEC-1906 Award for his contributions to the IEC standardization activities. He invented a variety of German, European and

international patents in the field of optical metrology instrumentation, and he has authored and co-authored numerous technical and scientific papers.

When I recently asked my favorite search engine for occurrences of the term "viewing angel" I got "about 19,200 English and German web-pages for "viewing angel" - most of them not obviously related to esoterics, but rather to the field of electronic display devices.

Contrast versus viewing direction: Since the early 1970s when LCDs started to move into consumer products like pocket calculators and wrist watches, there was the question on how to specify the range of viewing directions from which (among other quantities) the contrast of these device seemed to be sufficient. A first step to answering that question was the development of instruments that could provide measured data as basis for the rating of the electro-optical performance of LCDs of which the majority were operated in the reflective mode those days [1]. Since the contrast of LCDs is varying with viewing direction, the result of such evaluations was not a single number, but an array of results that needed to be understood, visualized and rated.

A convenient and intuitive way of visualization was adapted in 1979 from *conoscopy*, a technique for probing the optical properties of crystals as a function of the direction of light propagation, introduced into the field of liquid crystals by Maugin in the year 1911. In the *directions image* that is formed in the back focal plane of a polarizing microscope objective lens in the conoscopic mode of operation, each point corresponds to one specific direction of light propagation. In analogy to the *directions image (conoscopic image)* the results of the first measurements of LCD contrast versus viewing direction have been graphically represented as lines of equal contrast (i.e. *iso-contrast lines*) in a polar coordinate system [2]. This visualization is self-explaining and intuitive, and moreover it provides a direct relation to the interference figures well known from conoscopic observations of liquid crystalline layers (e.g. the "Maltese cross" that is formed when a twisted nematic structure approaches a homeotropic alignment under the effect of an increased electric field, see e.g. [3, 4]).

Sophisticated manufacturers of LCDs published one contrast contour diagram in their catalogues for each type of LCD and sometimes also for various driving voltages. From the variation of contrast with viewing direction a range of integral characteristics (e.g. average and directionally weighted average values) could be derived and specified according to the individual needs of the customer and the requirements of the application.

LCDs improved over time from hard-wired devices that could display numbers and symbols (with 7 to 16 segment electrode layouts) to gray-scale display and finally to full-color display with high spatial resolution. Metrology for such improving device performance and related evaluations also evolved over time with an emphasis on gray-scale reduction and inversion [5], and then on color fidelity [6] over a wide range of viewing directions for a variety of different LCD technologies [7] for demanding applications (e.g. medical diagnostics).

In the meantime, LCD monitors have made their way into the offices around the globe as computer monitors and early in 2008, for the first time, more LCD-based TV-sets have been sold on this planet than TV-sets with cathode rays tubes (CRTs) according to a Display Search announcement in February 2008.

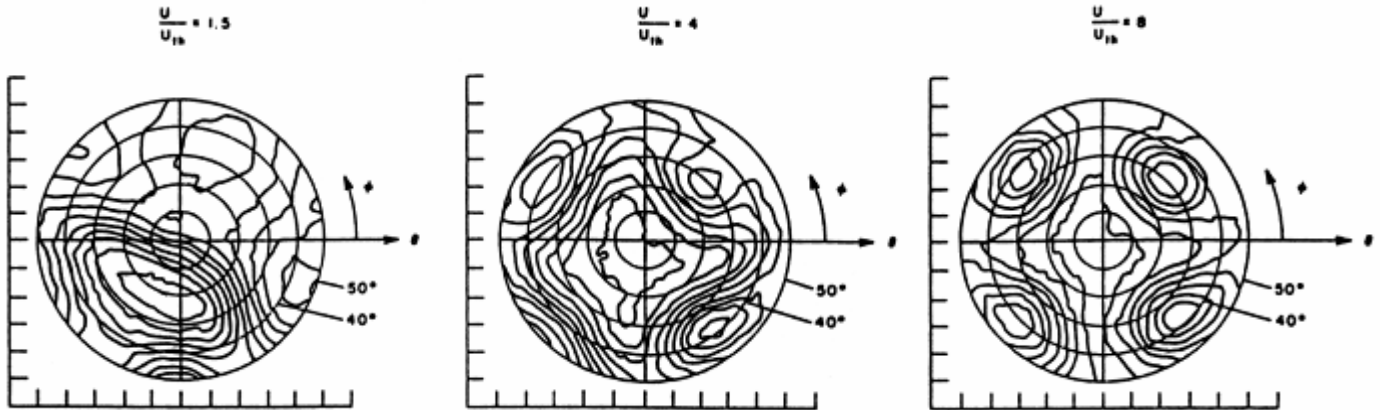

Figure 1: The first contrast contour diagrams measured with a motorized goniometric scanning device (DMS), from the diploma thesis of Michael E. Becker (University of Karlsruhe, 1979), then published in the first issue of Displays [2]. The measurements have been carried out for driving voltages of 1.5, 4 and 8 times the threshold voltage.

The increasing competition for better computer monitors and better TV-sets has also pushed the limits for the electro-optical properties of LCDs to limits that can only be overcome by visionary marketing specialists: many "viewing angle" specifications for LCD computer monitors and TV-sets have arrived at 178° and not yet trespassed that limit for reasons of deference, not however out of respect for the customer, common sense or even ergonomics.

So these days you can go to your local electronics supermarket and acquire a TV-set with "wide viewing angle $178^\circ \times 178^\circ$ " which surely sounds impressive, even though you might ask yourself why two degrees have been left missing to 180° .

From "viewing angle"... When a visual display with non-vanishing size is seen by an observer, every point of the display area is seen from a different direction as illustrated in Figure 2 for a cyclopic (i.e. one eyed) observer. The larger the display is and the closer the observer is to the display the more the viewing direction varies over the surface area of the display.

The *viewing direction* is specified by two polar angles: the angle of inclination, θ (measured from the surface normal of the display) and the azimuth angle, Φ , measured in the plane of the display as shown in Figures 2 and 3.

...to viewing cone: The multitude of directions from which a display can be seen without artifacts and distortions that would render its intended use impossible (e.g. computerized office work, television, entertainment) is called the *viewing cone* (even though its shape might be that of a generalized cone).

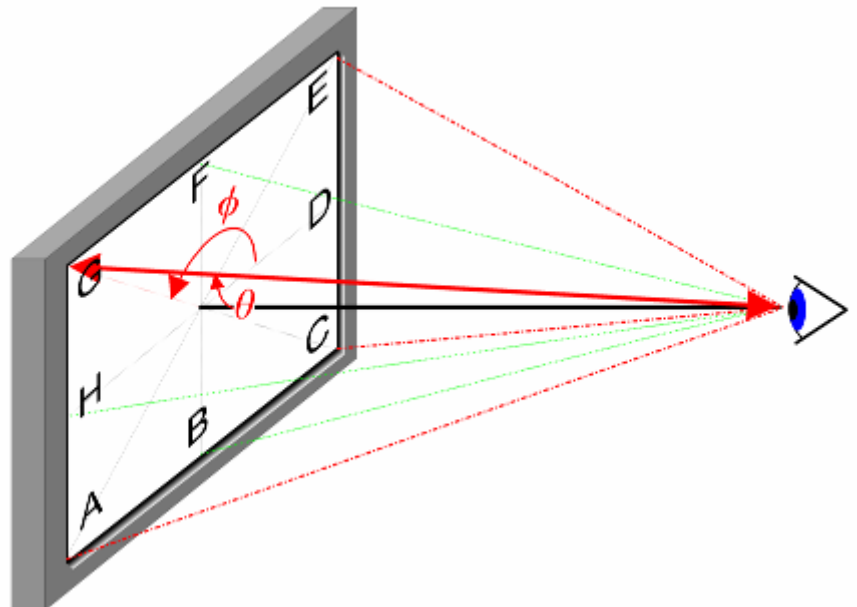

Figure 2: Illustration of the variation of the direction of observation (i.e. viewing direction) across the area of the display. All locations on the surface area of the display screen are seen from a different direction. The viewing direction is specified by an angle of inclination, θ (measured from the surface normal of the display) and the azimuth angle (in the surface plane of the display).

The concept of the *viewing cone* has been introduced for the first time in the international standard ISO 13406-2:2001 "Ergonomic requirements for work with visual displays based on flat panels - Part 2: Ergonomic requirements for flat panel displays". This standard provides a classification for computer monitors with LCDs according to the range of viewing directions that can safely be used for the intended task (here: office work) without "reduced visual performance". The classification is according to "Viewing Direction Range Classes" with the "range of viewing directions" being equivalent to the viewing cone.

ISO 13406-2 [8] describes a complex procedure according to which the usable viewing cone can be evaluated from measurements of luminance and chromaticity versus direction of observation. ISO 13406-2 introduces 4 viewing direction range classes of which the first (class I) features a *wide viewing cone* for a multitude of simultaneous observers and the last (class IV) is a so called "privacy display" with a severely limited viewing cone.

Depending on the actual task to be performed with a certain display device (e.g. office work, entertainment, home theater, etc.) the requirements for the display performance are different. Compliance routes for different display applications can now be found in the successor standard ISO 9241-300 [9] which has a scope that extends beyond office work.

Viewing directions are conveniently represented in a polar coordinate system with the angle of inclination, θ , being represented by the radial distance from the origin and the azimuth, Φ , increasing counterclockwise as shown in *Figure 4* with the x-axis being the reference direction (als called 3:00 direction). In this coordinate system every point corresponds to one viewing direction. A viewing cone is thus defined by a locus (a closed line) in this coordinate system as indicated by the rectangle and the ellipse in *Figure 4*. If a viewing cone is specified by four directions only (e.g. in the horizontal and the vertical plane), it does not become clear if it is the rectangle or the elliptical cone according to *Figure 4*. In order to resolve this ambiguity, the viewing cone should be specified by at least 8 directions, located in the horizontal and vertical plane and in the two diagonal planes ($\Phi = 45^\circ$ and 135°).

Each direction in the polar coordinate system of *Figure 4* can be assigned a (scalar) physical quantity, e.g. luminance, contrast, etc... This quantity can then be represented by lines of equal values (contour lines), by shades of gray or by pseudo-colors (as shown in *Figures 4 and 6*).

- A *viewing cone* can be defined starting from a certain application and the related geometry of observation, from which a range of directions can be derived specifying the *viewing cone* geometrically required for that task. Inside this viewing cone certain physical parameters that are related to the visual performance of the display device must remain within certain (task dependent) limits.

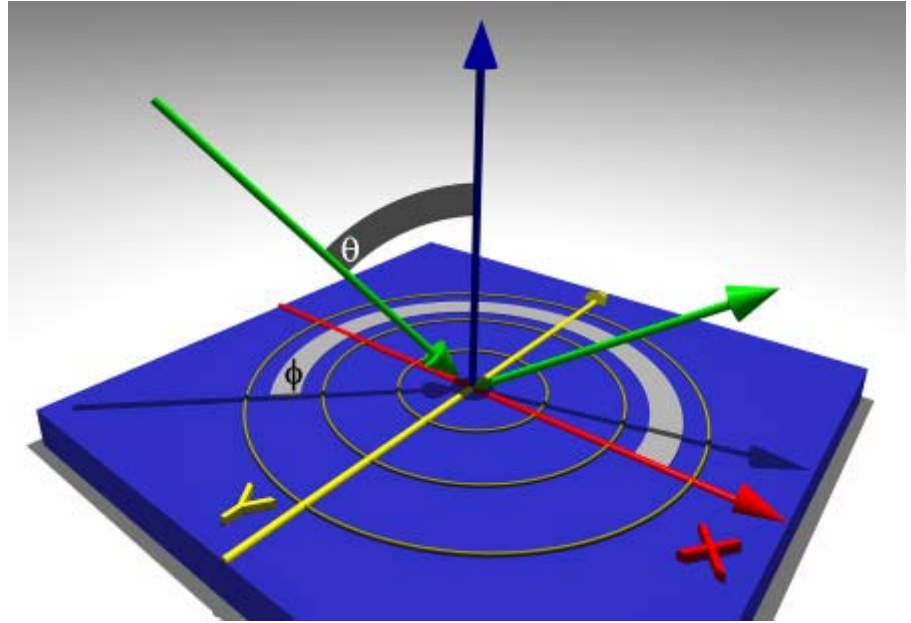

Figure 3: The green arrow on the left is the viewing direction (i.e. direction of observation) specified by the angle of inclination, θ , measured from the surface normal of the display (vertical arrow) while the azimuth angle, Φ , is the angle that the projection of the viewing direction onto the surface of the display makes with the x-axis. The projection of the viewing direction is shown here as the shadow of the green arrow. The azimuth angle Φ increases counterclockwise from the x-axis (3:00) as illustrated.

- A *viewing cone* can also result from measurements (versus viewing direction) carried out with a certain display device under specified operating conditions. Then the viewing cone is obtained by limiting values of a visual quantity (e.g. contrast), which for a certain application is required to be above e.g. 10 (compare e.g. VESA FPDM2 307-4 Viewing-cone thresholds). Then the line for which the contrast equals 10 defines the viewing cone.

Recent experiments [10] have shown that the acceptable viewing cone is rather determined by decrease of luminance and change of chromaticity than by the decrease of contrast.

Luminance, contrast and chromaticity versus viewing direction: *Figure 6* illustrates the variation of luminance and contrast of an IPS-LCD with viewing direction in a polar coordinate system. The left column shows the directional luminance distribution of the dark state of the display, the center column shows the bright state and the right column shows the (luminance) contrast (ratio) resulting from the preceding two luminance distributions. The values are coded by pseudo colors. The graphs below the polar coordinate systems each show the corresponding cross sections in the horizontal plane and indicate the numerical values for luminance and contrast. Each borderline between two shades of colors represents a line of constant value, in the case of contrast an iso-contrast (contour) line. Note, that "iso" is used here in the sense of "equal", it does NOT establish any relation to the International Organization for Standardization, ISO.

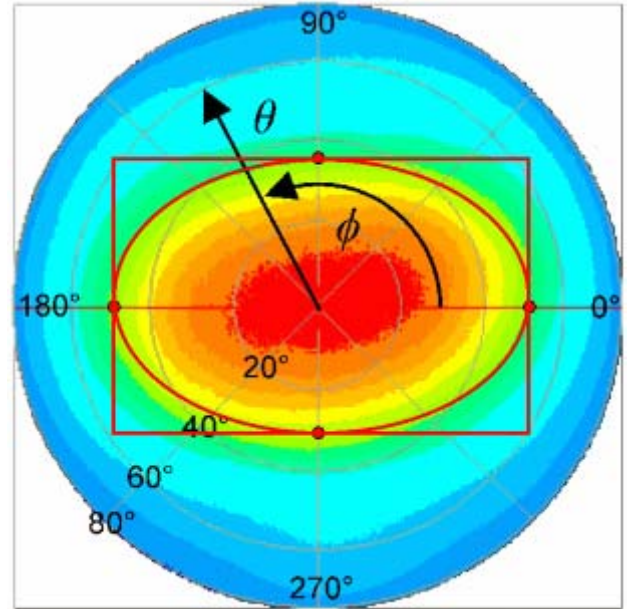

Figure 4: Illustration of the specification of the range of viewing directions (aka viewing cone) in a polar coordinate system. Each point in this coordinate system corresponds to a viewing direction with the distance from the center representing the respective angle of inclination, θ , and the azimuth, Φ . The pseudo-colors represent the value of a physical quantity (e.g. luminance) for each viewing direction.

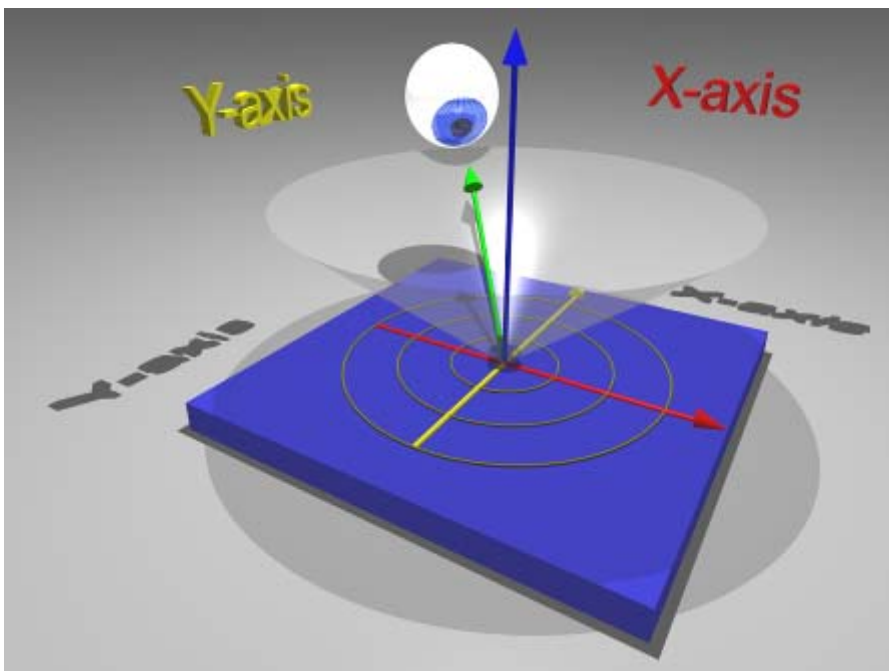

Figure 5: Illustration of an example of a viewing cone centered about the surface-normal of the display. This viewing cone can be represented in a polar coordinate system (e.g. fig. 4) by a circle around the center with the angle of inclination as radius. In general, a viewing cone may be tilted and distorted, i.e. of a less regular shape than shown here.

Since chromaticity is a vectorial quantity and thus cannot be represented in a single polar coordinate system it is convenient to resort to e.g. the color difference with respect to a reference direction (e.g. ΔE^* with respect to the normal viewing direction), or to represent each component of the chromaticity (e.g. u' , v') in a separate polar coordinate system.

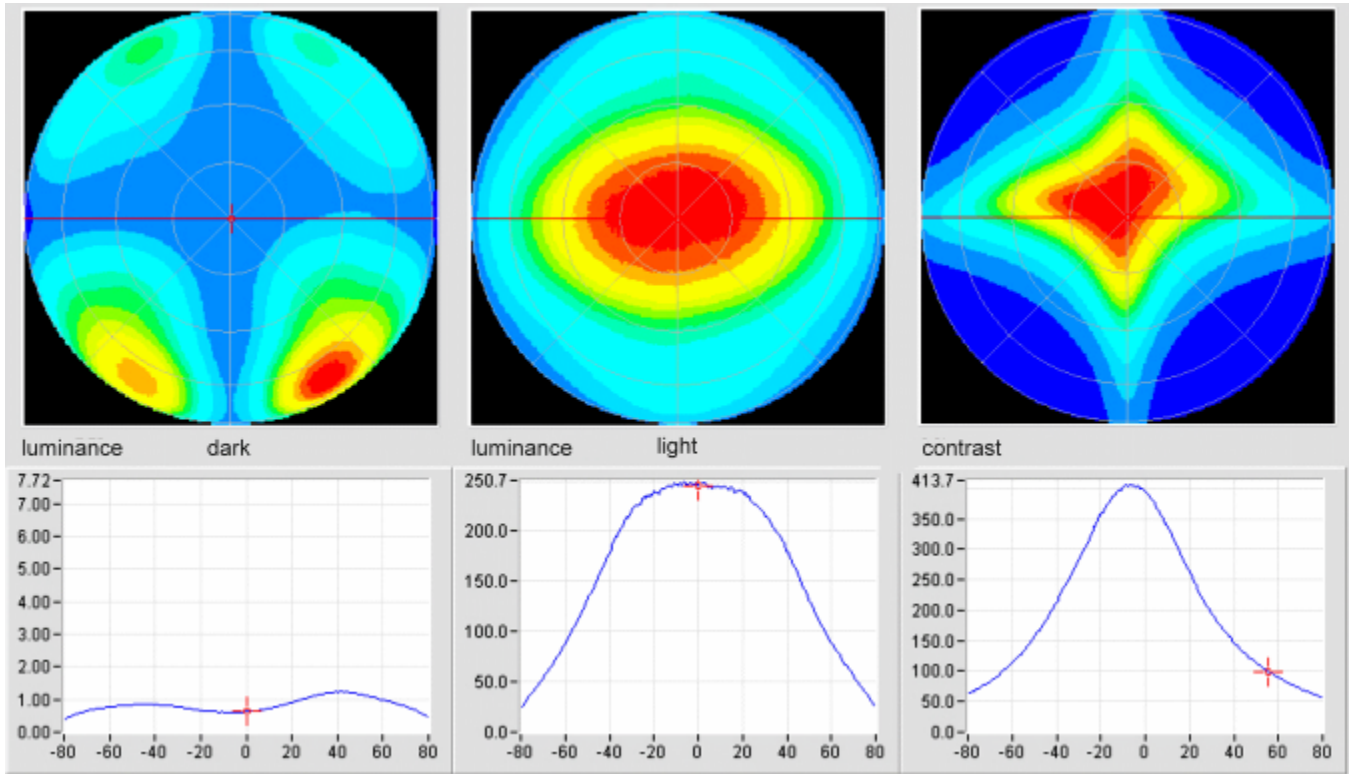

Figure 6: Luminance and contrast versus viewing direction in a polar coordinate system. The left column shows the directional luminance distribution of the dark state of the display (IPS LCD), the center column shows the bright state and the right column shows the (luminance) contrast (ratio) resulting from the preceding two luminance distributions. The values are coded by pseudo colors. The graphs below the polar coordinate systems each show a cross section in the horizontal plane and indicate the values for luminance and for the contrast. Each borderline between two shades of colors represents a line of constant value, in the case of contrast an iso-contrast (contour) line. Note, that "iso" is used in the sense of "equal", it does NOT establish any relation to the International Organisation for Standardization, ISO.

These evaluations have been carried out with a ConoScope from Autronic-Melchers.

Trimming the wings of the "viewing angel": Since there is no international standard to which the numbers "178° x 178°" from LCD data-sheets refer to, they are as meaningless for the actual application as they are supposed to be impressive. It is assumed that in most of the cases the numbers "178° x 178°" are meant to specify the angle of inclination for which the contrast reaches the limiting value of 10. This however does not provide any information about luminance and chromaticity at these angles of inclination and thus does not specify the visual performance of the display.

When two numbers are encountered in such "specifications" they sometimes come with indices "h" and "v", which means that the numbers are supposed to specify two ranges of the angle of inclination in the horizontal and vertical plane, i.e. at values of the azimuth angle of 0° and 180° (horizontal plane) and of 90° and 270° (vertical plane). When an LCD-monitor is used for office work it should be taken into account that, at an angle of inclination of 45°, any character displayed on the screen is appearing foreshortened by ~30%, a purely geometrical effect which is limiting the usability of the display even with all electro-optical characteristics remaining constant.

In a recent comprehensive investigation initiated by Philips (Consumer Electronics and Research Laboratories), comparisons between experiments and measurements have been carried out in order to identify the quantities and

the corresponding limiting values that define the apparent *viewing cone* for television screens with LCDs and PDPs [10]. One of the results is that "the luminance at intermediate-to-high gray levels determines the viewing-direction dependent quality and not the contrast ratio." This is found to be in agreement with other research results that "find a low correlation between contrast ratio and visual assessment value". Furthermore, "not only the chromaticity coordinates of the primaries, but even more those of the white point play an important role and need to be included in a viewing direction dependent metric". The authors conclude that "for LCDs, this new metric results in a viewing cone, which is on the order of 70°–90° (subtended angle), and thus, considerably lower than what is usually specified based on a minimum contrast of 10. For PDPs, this new metric yields the same viewing direction range as the present specification that uses a luminance decrease to 50%".

In the terminology as introduced above (and illustrated in *Figure 5*) a viewing cone of 70°–90° subtended angle means (for a rotationally symmetric viewing cone) a maximum angle of inclination of 35°–45°.

Conclusions:

- The *viewing cone* is a range of *viewing directions* that satisfies specific task dependent performance requirements.
- The *viewing cone* shall be specified by at least four directions, it should preferably be specified by 8 directions (see *Figure 4*).
- Any specification of a *viewing cone* requires the specification of the related limiting values and quantities (minimum of luminance, contrast, limit values for chromaticity, etc.).
- Exaggerated *viewing cone* specifications found in data sheets (e.g. "178° x 178°") are meaningless since they are based on an (equally meaningless) contrast limit of 10.
- More reasonable evaluations show that the *viewing cone* of state-of-the-art LCDs are in the range of 70° - 90° subtended angle of inclination.
- The international standard ISO 9241-300 (FDIS stage) supports the definition of a variety of viewing cones for electronic display devices in dependence of the intended application. This standard should be taken into consideration after its final release.



References:

- [1] J. Laur: *Measuring and rating electro-optical display performance*, Information Display Magazine, 2(2008), pp. 22-25
- [2] R. Cremers, et al.: *A new method for characterization and evaluation of the optical appearance of reflective TN-LCDs*, Displays 1979, pp. 12-14
- [3] A. R. Kmetz, *Characterization and Optimization of Twisted Nematic Displays for Multiplexing*, SID'78 Digest, pp. 70-71
- [4] P. A. Penz, *A figure of merit characterizing the anisotropic viewing properties of the twisted nematic LCD*, SID'78 Digest, pp. 68-69
- [5] J. Hirata, et. al., *Viewing-angle evaluation method for LCDs with grey-scale image*, Proc. SID'93, pp. 561-564
- [6] T. Fiske, L. Silverstein, *Characterization of viewing-angle dependent colorimetric and photometric performance of color LCDs*, Proc. SID'93, pp. 565-568
- [7] S. L. Wright, et al., *Status of TFTLCD Color and Metrology*, IBM Research Report RC 21718 (97804), 6 April 2000
- [8] ISO 13406-2:2000 "Ergonomic requirements for work with visual displays based on flat panels -- Part 2: Ergonomic requirements for flat panel displays."
- [9] ISO 9241-300: "Ergonomics of human-system interaction -- Part 300: Introduction to electronic visual display requirements." The ISO 9241-300 series establishes requirements for the ergonomic design of electronic visual displays. These requirements are stated as performance specifications, aimed at ensuring effective and comfortable viewing conditions for users with normal or adjusted-to-normal eyesight. Test methods and metrology, yielding conformance measurements and criteria, are provided for design evaluation. ISO 9241 is applicable to the visual ergonomics design of electronic visual displays for a diversity of tasks in a wide variety of work environments.
- [10] K. Teunissen, et al., *A perceptually based metric to characterize the viewing-angle range of matrix displays*, JSID 16/1(2008), pp. 27-36